



WMF COFFEE MACHINES

Base Information

WMF CombiNation F Type 8700



WMF CombiNation F

Application

Filter Coffee & Hot Water
suitable for Self Service

Capacity

for outlets up to 500 Cups per Hour

Service Period

Approximately 100,000 Cups

The new WMF CombiNation F creates a completely new dimension in aromatic filter coffee from one of the most fashionable all-automatic coffee machines on the market. The timeless, aesthetically perfect design also promotes hitherto inconceivable user-friendliness. The concave form of the front panel ensures an optimum overview and concentrates the user's attention on the large, easy-to-operate product keys and the touchscreen display. The operating status and the set brewing quantity can be read off here and changed at any time. Surely the simplest way of discovering a whole new world of taste. If you also wish to prepare top-quality coffee specialities in addition to filter coffee, simply combine the WMF CombiNation F with the WMF combiNation E.

TECHNICAL DATA

Standard Models

Hourly Output

Product Containers

Dimension

Connections

Options

	9.3 kW	13.8 kW
Filter Coffee	430 Cups/h	500 Cups/h
Hot Water Capacity	72 L/h	108 L/h
Choc (optional)		120 Cups/h
Coffee Powder Hopper		2.2 kg
Storage Container		4.0 Litres
Height x Width x Depth	450 x 810 x 590 mm	
Weight	~ 68 kg	
Power Supply	3P/N/E 400V 50/60 Hz	3P/N/E 400V 50/60 Hz
Water Suppl	1/2" (minimum 1.5 bar)	
Drainage	25 mm	
Height adjustable Front Panel	YES	YES
Granulate Cleaning	YES	YES
Mobile Station	NO	NO
Cup Rack	YES	YES
Choc Dispenser	YES	YES

WMF AG Coffee Machines International 73312 Geislingen/Steige, Germany

Phone +41 7331 258482 Fax +41 7331 258792, Mail: professional@wmf.com, Web: <http://www.wmf.com>

Service Agent: RICMAS International Pte. Ltd. 25 International Business Park, German Centre #01-07/10, Singapore 609916

Phone: +65 65628853, Fax: +65 65628854, Mail: wmf@ricmas.com, Web: <http://www.ricmas.com>



WMF COFFEE MACHINES

Planing Information

WMF CombiNation F Type 8700

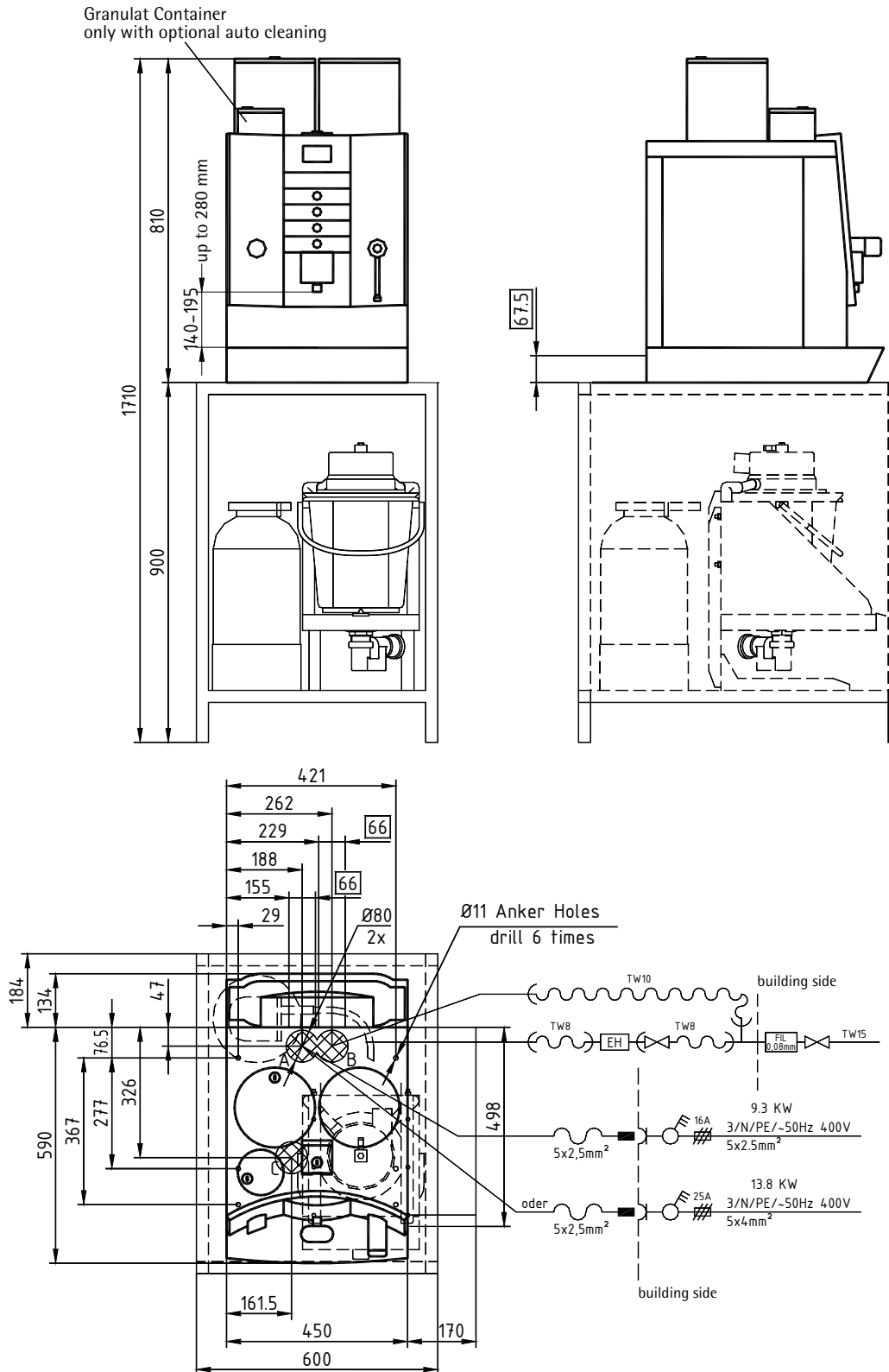

WMF AG Coffee Machines International 73312 Geislingen/Steige, Germany

Phone +41 7331 258482 Fax +41 7331 258792, Mail: professional@wmf.com, Web: <http://www.wmf.com>

Service Agent: RICMAS International Pte. Ltd. 25 International Business Park, German Centre #01-07/10, Singapore 609916

Phone: +65 65628853, Fax: +65 65628854, Mail: wmf@ricmas.com, Web: <http://www.ricmas.com>



WMF COFFEE MACHINES

Data Sheet

WMF CombiNation F Type 8700

Brewing process:	filtered coffee
Output per hour:	maximum 500 cups of filter coffee, 108 L hot-water output, total (13.8 kW) maximum 430 cups of filter coffee, 72 L hot-water output, total (9.3 kW)
Option:	self-service model, without or fitted with cashless payment with cards or bank card reader or coin checker / changer
Accessories:	water softener, sediment separator, chocolate dispenser, cupboard
Degree of protection:	IPX0
Protection class:	Protection class I
Perceptible heat emission:	0.2 kW/h in standby mode
Perceptible heat emission:	9.15 kWh/h in maximum mode for all types with rated power 9.3 kW 13.65 kWh/h in maximum mode for all types with rated power 13.8 kW
Cont. sound level (Lpa)	< 65 dB (A)
Water connection:	1/2" (TW 15)
Flow pressure:	at least 0.2 MPa, at 8 L min., maximum 0.6 MPa
Miscellaneous:	wet coffee grounds discharge
Drain:	DN 40 (1 1/2"), gradient at least 2%
Empty weight:	ca. 68 kg