



WMF COFFEE MACHINES

Base Information

WMF Universal Cooler 9192



WMF Universal Cooler

Application

Universal Milk Cooler for models like prestolino!, presto! and bistro!

Capacity

6.5 Litres of Milk

This universal milk cooler comes with an automatic temperature control from 2° - 6°C which keeps the milk at the optimal temperature. The removable milk tank with approximately 6.5 litres capacity is prepared for Plug & Clean operation and is dishwasher-proof. The cooler got a on/off switch and a temperature control button.

The universal milk cooler is also available with a door lock for self service operation.

TECHNICAL DATA

Type:	03.9192.0001 Universal Cooler 6.5 L for prestolino!, presto! or bistro! 1/N/PE, 50Hz, 230V, 0,09 kW, Fuse 16 A
Capacity:	Milk insert 6.5 L with cover for Plug & Clean
Option:	Lockable door for Self Service operation
Degree of protection:	IPX0
Protection class:	Protection class I
Perceptible heat emission:	0.015 kWh/h in maximum mode
Cont. Sound level (Lpa):	<60 dB (A)
Others:	The universal cooler can only be installed on the left hand side of the coffee machine. Power cord 1.4 m
Weight empty:	16.5 kg

WMF AG Coffee Machines International 73312 Geislingen/Steige, Germany

Phone +41 7331 258482 Fax +41 7331 258792, Mail: professional@wmf.com, Web: <http://www.wmf.com>
Service Agent: RICMAS International Pte. Ltd. 25 International Business Park, German Centre #01-07/10, Singapore 609916
Phone: +65 65628853, Fax: +65 65628854, Mail: wmf@ricmas.com, Web: <http://www.ricmas.com>



WMF COFFEE MACHINES

Planing Information

WMF universal Milk Cooler Type 9192

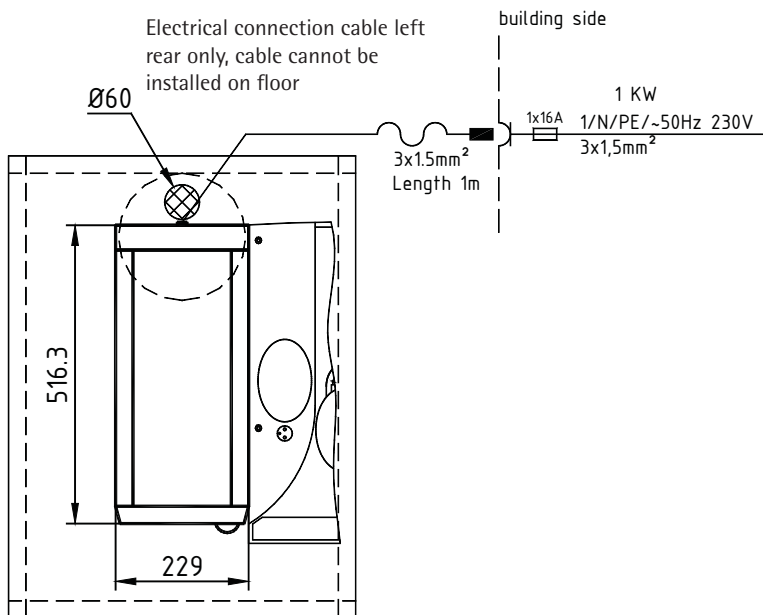
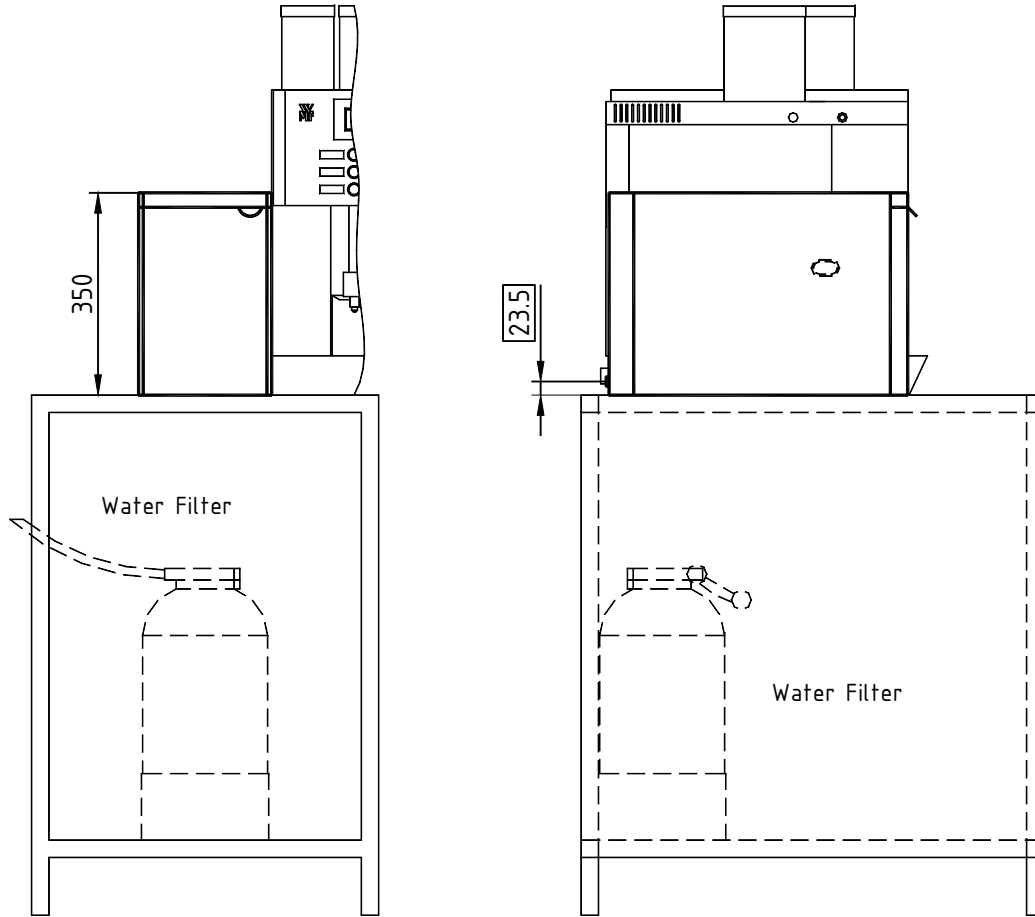

WMF AG Coffee Machines International 73312 Geislingen/Steige, Germany

Phone +41 7331 258482 Fax +41 7331 258792, Mail: professional@wmf.com, Web: <http://www.wmf.com>

Service Agent: RICMAS International Pte. Ltd. 25 International Business Park, German Centre #01-07/10, Singapore 609916

Phone: +65 65628853, Fax: +65 65628854, Mail: wmf@ricmas.com, Web: <http://www.ricmas.com>